

M70/H52 316 Stainless steel pump



FIELD OF APPLICATION

Pump with 2:1 **hygienic design**, it is quickly disassembled for cleaning or sanitizing the single components. Easy to handle and versatile, it has **variable flow rates up to 23 l/min** (water). It is also suitable for insertion into closed jugs with holes 2". It can be used for **low and medium viscosity fluids (up to 40.000 cP)** is made in **AISI 316 Stainless steel** suitable for any **food or cosmetic product**, as well as for medical-health use.

MAIN FEATURES OF HYGIENE PUMPS

They are **pumps based on a new design**, created to be quickly disassembled by hand without the need for any special tools. The functional concept is based on an alternating piston with ball check valves, the **flow and head are adjustable**, they are designed for **viscous food products and cosmetic fluids** or also for production processes for **medical creams**. The part in contact with the product is made entirely in **AISI 316 Stainless steel**, the **FDA gasket seals** are made in **NBR** or **FKM, UHMWPE**, or **PTFE**.

The **gasket seal on the shaft does not require adjustment**, and is efficient with any viscosity and pressure, and also is long-lasting. These pumps do not require any special maintenance, are sturdy, and reliable, **easy to disassemble for periodical cleaning or for sanitizing the single components**. The complete range can be supplied with **ATEX Zone 1 certification** for the motor section and **ATEX Zone 0** for the pump immersed in liquid. This therefore makes them **suitable for use in potentially explosive atmospheres**.

They are used by immersing the pumping piston in the fluid, or also outside of the product container. For the latter use, we can supply **Stainless steel fittings and flexible hoses** to connect the suction and the outlet. We can supply a **transport trolley**, or a **cushioned support for wall mounting**.

For efficient and safe use, we recommend our **pneumatic elevator on wheels or fixed on the ground**.

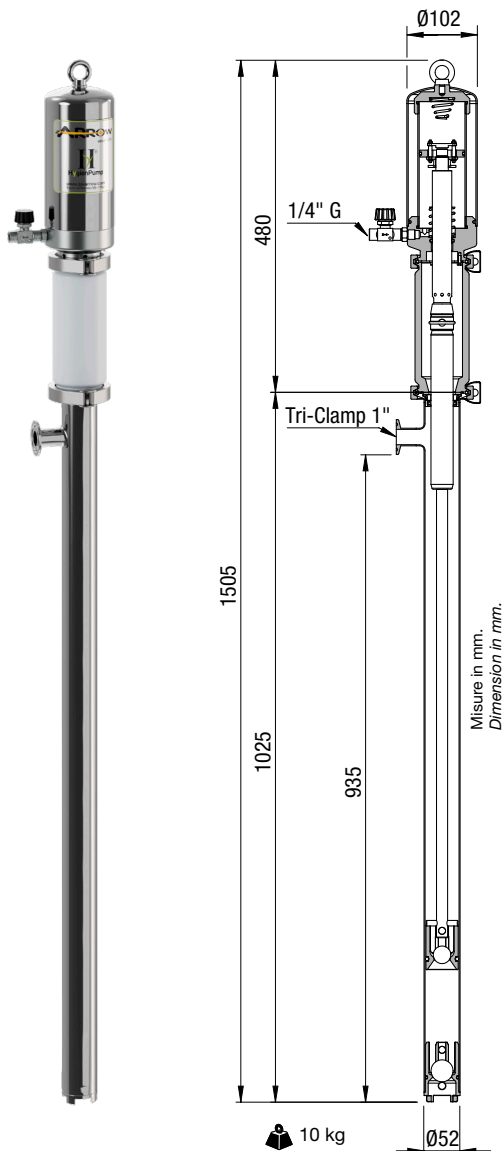

TECHNICAL DATA

Maximum cycles/minute	120 cycles/min
Air consumption at 120 cycles/min	0,45 Nm ³ / min - Power supply 6 bar (87 psi)
Delivery at 120 cycles/min	23 liters/min (Free flowing water)
Delivery per cycle	0,188 liters per Cycle (Free flowing water)
Ambient temperature	0 °C at + 40 °C
Maximum fluid temperature	+ 85 °C
Fluid outlet	1" Tri-Clamp
Compression ratio	2:1
Air inlet	1/4" G
Air pressure	up to 7 bar (100 psi)
Pump components	316 Stainless steel with parts in PTFE, UHMWPE, FKM, NBR FDA

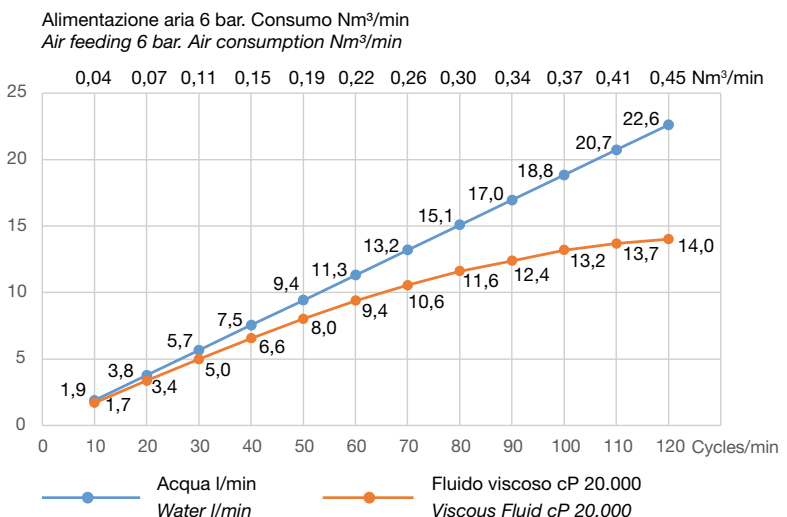

Z.P. ARROW s.r.l. via Giolitti 15 - 36056
Tezze sul Brenta (VI) Italia
www.zp-arrow.com - arrow@zp-arrow.com

